

Specifications

Features

- Top Mount
- 20 gauge stainless steel
- Durable Satin Finish
- 7-1/2" (191mm) Depth
- Overall Size: 15" x 15" (381mm x 381mm)
- 2" (51mm) center drain opening
- Includes basket strainer
- Faucet holes: (2) 1-1/4" (32mm) diameter
- Cutout Dimensions: 14-3/8" x 14-3/8" (365mm x 365mm) with 1-1/2" (38mm) radius corners.
- Mounting hardware for countertops up to 3/4" (19mm) thick included.
- Sound insulation - spray undercoating on bottom
- Minimum cabinet size: 18" (457mm)
- Limited lifetime warranty

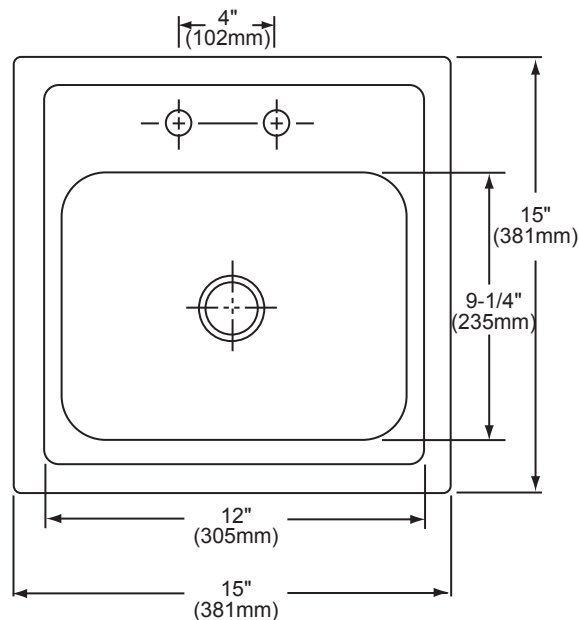

In keeping with our policy of continuing product improvement, Revere reserves the right to change product specifications without notice. Please visit reversesink.com for most current version of Revere product specification sheets.

This specification describes a Revere product with design, quality, and functional benefits to the user. When making a comparison of others producers offerings, be certain these features are not overlooked.