



Undermount Model Double Bowl Sink NCFU3119L/NCFU3119R

Specifications

FEATURES:

- 18 (1.2mm) gauge nickel-bearing stainless steel
- 8" (203mm) deep
- Satin finish
- 3-1/2" (89mm) drain opening
- Sound dampening pad with spray undercoating
- Minimum cabinet size: 36" (914mm)

OPTIONAL ACCESSORIES:

- Mounting Brackets: LKUMB8 (2)

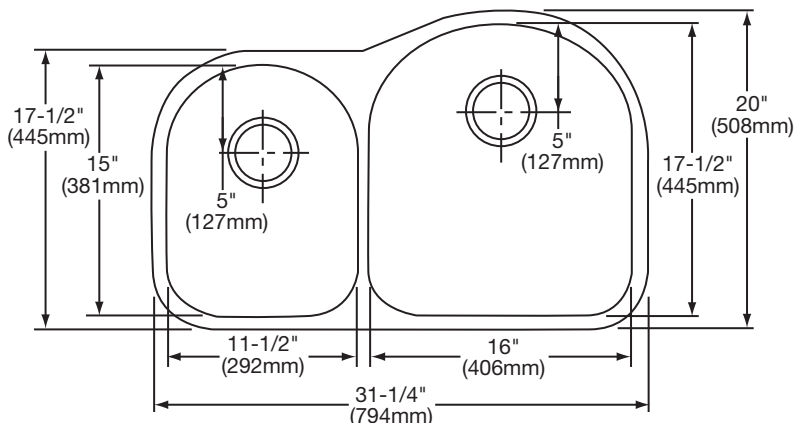

NCFU3119L Illustrated

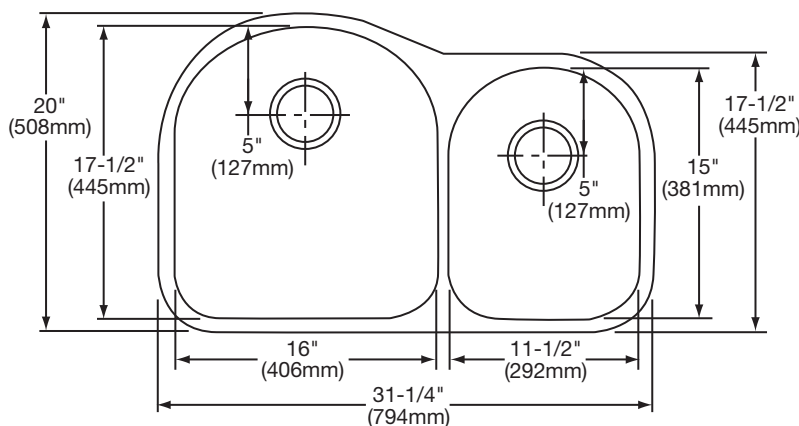

NCFU3119R Illustrated

Installation Profile

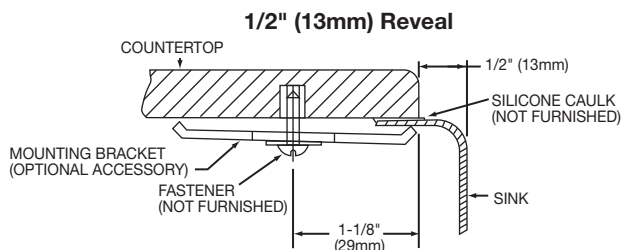

NOTE: THIS UNDERMOUNT SINK IS DESIGNED TO MOUNT TO SOLID SURFACE (NON-LAMINATE) COUNTERTOP ONLY.

In keeping with our policy of continuing product improvement, Revere reserves the right to change product specifications without notice.

This specification describes a Revere product with design, quality and functional benefits to the user. When making a comparison of other producers' offerings, be certain these features are not overlooked.

Revere • 2222 Camden Ct. • Oak Brook, IL 60523 • reverssink.com • Tel: (800) 225-8585 • Fax: (630) 645-4447